

Manual
user instructions.

baltur
TECNOLOGIE PER IL CLIMA

BT 350 DSG

TWO-STAGE DIESEL BURNER



ISTRUZIONI ORIGINALI (IT)

98318_201204



- Before starting to use the burner for the first time, read carefully the chapter “WARNING NOTES FOR THE USER: HOW TO USE THE BURNER SAFELY” in this instruction manual, which is an integral and essential part of the product.
- Read carefully the instructions before starting the burner and servicing it.
- The works on the burner and on the system should be carried out only by qualified personnel.
- The system power supply must be disconnected before starting working. If the works are not carried out correctly it is possible to cause dangerous accidents.

Declaration of Conformity

We declare that our products

**BPM...; BGN...; BT...; BTG...; BTL...; TBML...; Comist...;
GI...; GI...Mist; Minicomist...; PYR...; RiNOx...; Spark...;
Sparkgas...; TBG...; TBL...; TBML ...; TS...; IBR...; IB...
(Variant: ... LX, for low NOx emissions)**

Description:

forced air burners of liquid, gaseous and mixed fuels for residential and industrial use meet the minimum requirements of the European Directives:

**2009/142/CE(D.A.G.)
2004/108/CE.....(C.E.M.)
2006/95/CE.....(D.B.T.)
2006/42/CE(D.M.)**

and conform to European Standards:

**UNI EN 676:2008 (gas and combination, gas side)
UNI EN 267:2002 (diesel and combination, diesel side)**

These products are therefore marked:



0085

18/11/2010

Dr. Riccardo Fava
Managing Director / CEO

TECHNICAL SPECIFICATIONS.....	4
PRELIMINARY REMARKS FOR A PROPER INSTALLATION.....	6
FIXING THE BURNER TO THE BOILER.....	6
ELECTRICAL CONNECTIONS.....	7
FUEL PIPELINES (DIESEL).....	7
AUXILIARY PUMP.....	7
OPERATION DESCRIPTION.....	9
IGNITION AND ADJUSTMENT.....	11
ADJUSTING THE DISTANCE BETWEEN DISK AND NOZZLE - ADJUSTING THE AIR ON THE COMBUSTION HEAD.....	12
CHECKS - USING THE BURNER.....	12
MAINTENANCE.....	13
DESCRIPTION OF THE TWO-STAGE BURNER OPERATION.....	13
TROUBLESHOOTING.....	14
BALTUR PUMP MODEL BT.....	17
NOZZLE FLOW-RATE TABLE FOR DIESEL FUEL.....	18
WIRING DIAGRAM.....	20



WARNING NOTES FOR THE USER HOW TO USE THE BURNER SAFELY

FOREWORD

These warning notes are aimed at ensuring the safe use of the components of heating systems for civil use and the production of hot water. They indicate how to act to avoid the essential safety of the components being compromised by incorrect or erroneous installation and by improper or unreasonable use. The warning notes provided in this guide also seek to make the consumer more aware of safety problems in general, using necessarily technical but easily understood language. The manufacturer is not liable contractually or extra contractually for any damage caused by errors in installation and in use, or where there has been any failure to follow the manufacturer's instructions.

GENERAL WARNING NOTES

- The instruction booklet is an integral and essential part of the product and must be given to the user. Carefully read the warnings in the booklet as they contain important information regarding safe installation, use and maintenance. Keep the booklet to hand for consultation when needed.
- Equipment must be installed in accordance with current regulations, with the manufacturer's instructions and by qualified technicians. By the term 'qualified technicians' is meant persons that are competent in the field of heating components for civil use and for the production of hot water and, in particular, assistance centres authorised by the manufacturer. Incorrect installation may cause damage or injury to persons, animals or things. The manufacturer will not in such cases be liable.
- After removing all the packaging make sure the contents are complete and intact. If in doubt do not use the equipment and return it to the supplier. The packaging materials (wooden crates, nails, staples, plastic bags, expanded polystyrene, etc.) must not be left within reach of children as they may be dangerous to them. They should also be collected and disposed on in suitably prepared places so that they do not pollute the environment.
- Before carrying out any cleaning or maintenance, switch off the equipment at the mains supply, using the system's switch or shut-off systems.
- If there is any fault or if the equipment is not working properly, deactivate the equipment and do not attempt to repair it or tamper with it directly. In such case get in touch with only qualified technicians. Any product repairs must only be carried out by BALTUR authorised assistance centres using only original spare parts. Failure to act as above may jeopardise the safety of the equipment. To ensure the efficiency and correct working of the equipment, it is essential to have periodic maintenance carried out by qualified technicians following the manufacturer's instructions.
- If the equipment is sold or transferred to another owner or if the owner moves and leaves the equipment, make sure that the booklet always goes with the equipment so it can be consulted by the new owner and/or installer.
- For all equipment with optionals or kits (including electrical), only original accessories must be used.

BURNERS

- This equipment must be used only for its expressly stated use: applied to boilers, hot air boilers, ovens or other similar equipment and not exposed to atmospheric agents. Any other use must be regarded as improper use and hence dangerous.
- The burner must be installed in a suitable room that has ventilation in accordance with current regulations and in any case sufficient to ensure correct combustion
- Do not obstruct or reduce the size of the burner' air intake grills or the ventilation openings for the room where a burner or a boiler is installed or dangerous mixtures of toxic and explosive gases may form.
- Before connecting the burner check that the details on the plate correspond to those of the utility supplies (electricity, gas, light oil or other fuel).
- Do not touch hot parts of the burner. These, normally in the areas near to the flame and any fuel pre-heating system, become hot when the equipment is working and stay hot for some time after the burner has stopped.
- If it is decided not to use the burner any more, the following actions must be performed by qualified technicians:
 - a) Switch off the electrical supply by disconnecting the power cable from the master switch.
 - b) Cut off the fuel supply using the shut-off valve and remove the control wheels from their position.
 - c) Render harmless any potentially dangerous parts.

Special warning notes

- Check that the person who carried out the installation of the burner fixed it securely to the heat generator so that the flame is generated inside the combustion chamber of the generator itself.
- Before starting up the burner, and at least once a year, have qualified technicians perform the following operations:
 - a) Set the burner fuel capacity to the power required by the heat generator.
 - b) Adjust the combustion air flow to obtain combustion yield of at least the minimum set by current regulations.
 - c) Carry out a check on combustion to ensure the production of noxious or polluting unburnt gases does not exceed limits permitted by current regulations.
 - d) Check the adjustment and safety devices are working properly.
 - e) Check the efficiency of the combustion products exhaust duct.
 - f) Check at the end of the adjustments that all the adjustment devices mechanical securing systems are properly tightened.
 - g) Make sure that the use and maintenance manual for the burner is in the boiler room.
- If the burner repeatedly stops in lock-out, do not keep trying to manually reset but call a qualified technicians to sort out the problem.
- The running and maintenance of the equipment must only be carried out by qualified technicians, in compliance with current regulations.



WARNING NOTES FOR THE USER HOW TO USE THE BURNER SAFELY

ELECTRICAL SUPPLY

- The equipment is electrically safe only when it is correctly connected to an efficient ground connection carried out in accordance with current safety regulations. It is necessary to check this essential safety requirement. If in doubt, call for a careful electrical check by a qualified technicians, since the manufacturer will not be liable for any damage caused by a poor ground connection.
- Have qualified technicians check that the wiring is suitable for the maximum power absorption of the equipment, as indicated in the technical plate, making sure in particular that the diameter of cables is sufficient for the equipment's power absorption.
- Adapters, multiple plugs and extension cables may not be used for the equipment's power supply.
- An omnipolar switch in accordance with current safety regulations is required for the mains supply connection.
- The electrical supply to the burner must have neutral to ground connection. If the ionisation current has control with neutral not to ground it is essential to make a connection between terminal 2 (neutral) and the ground for the RC circuit.
- The use of any components that use electricity means that certain fundamental rules have to followed, including the following:
 - do not touch the equipment with parts of the body that are wet or damp or with damp feet
 - do not pull on electrical cables
 - do not leave the equipment exposed to atmospheric agents (such as rain or sun etc.) unless there is express provision for this.
 - do not allow the equipment to be used by children or inexperienced persons.
- The power supply cable for the equipment not must be replaced by the user. If the cable gets damaged, switch off the equipment, and call only on qualified technicians for its replacement.
- If you decide not to use the equipment for a while it is advisable to switch off the electrical power supply to all components in the system that use electricity (pumps, burner, etc.).

GAS, LIGHT OIL, OR OTHER FUEL SUPPLIES

General warning notes

- Installation of the burner must be carried out by qualified technicians and in compliance with current law and regulations, since incorrect installation may cause damage to person, animals or things, for which damage the manufacturer shall not can be held responsible.
- Before installation it is advisable to carry out careful internal cleaning of all tubing for the fuel feed system to remove any residues that could jeopardise the proper working of the burner.
- For first start up of the equipment have qualified technicians carry out the following checks:
- If you decide not to use the burner for a while, close the tap or taps that supply the fuel.

Special warning notes when using gas

- Have qualified technicians check the following:
 - a) that the feed line and the train comply with current law and regulations.
 - b) that all the gas connections are properly sealed.
- Do not use the gas pipes to ground electrical equipment.
- Do not leave the equipment on when it is not in use and always close the gas tap.
- If the user of is away for some time, close the main gas feed tap to the burner.
- If you smell gas:
 - a) do not use any electrical switches, the telephone or any other object that could produce a spark;
 - b) immediately open doors and windows to create a current of air that will purify the room;
 - c) close the gas taps;
 - d) ask for the help of qualified technicians.
- Do not block ventilation openings in the room where there is gas equipment or dangerous situations may arise with the build up of toxic and explosive mixtures.

FLUES FOR HIGH EFFICIENCY BOILERS AND SIMILAR

It should be pointed out that high efficiency boilers and similar discharge combustion products (fumes) at relatively low temperatures into the flue. In the above situation, traditional flues (in terms of their diameter and heat insulation) may be suitable because the significant cooling of the combustion products in these permits temperatures to fall even below the condensation point. In a flue that works with condensation there is soot at the point the exhaust reaches the atmosphere when burning light oil or heavy oil or the presence of condensate water along the flue itself when gas is being burnt (methane, LPG, etc.). Flues connected to high efficiency boilers and similar must therefore be of a size (section and heat insulation) for the specific use to avoid such problems as those described above.

TECHNICAL SPECIFICATIONS

		BT 350 DSG
FLOW RATE	MIN Kg/h	115
	MAX Kg/h	350
HEATING CAPACITY	MIN kW	1364
	MAX kW	4151
FUEL VISCOSITY	DIESEL FUEL	1.5°E - 20°C
FAN MOTOR	50Hz	9.2 kW - 2910 r.p.m.
IGNITION TRANSFORMER	VOLT	14 kV - 30mA - 230V - 50Hz
VOLTAGE		3N ~ 400 V - 50 Hz

STANDARD ACCESSORIES	BT 350 DSG
BURNER COUPLING FLANGE	No. 1
INSULATING GASKET	No. 2
STUD BOLTS	No. 4 - M20
HEXAGONAL NUTS	No. 4 - M20
FLAT WASHERS	N° 4 - M 20
FLEXIBLE PIPES	No.2 - 1" ¼ L 1500
FILTER	1"¼

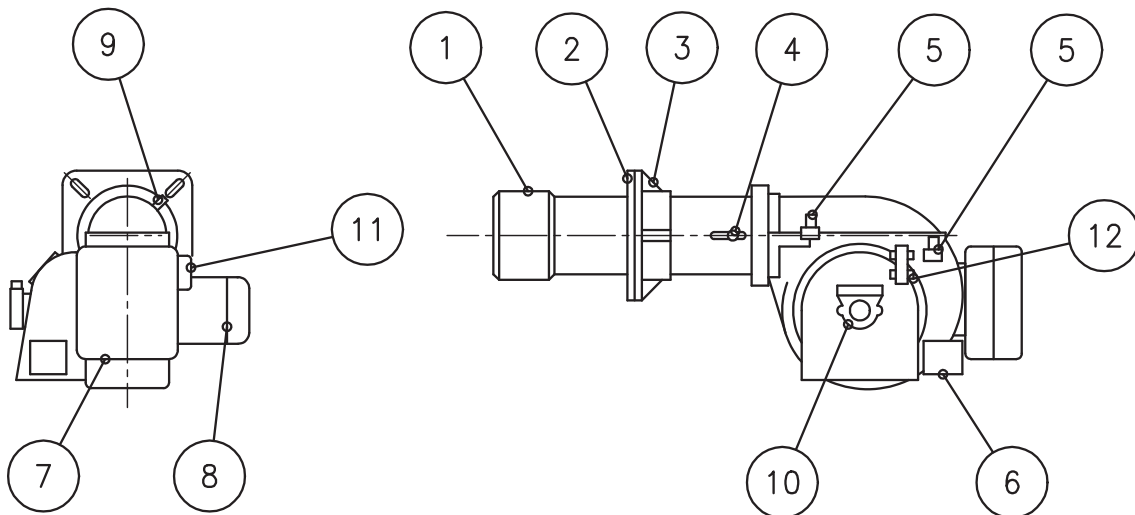

- | | |
|------------------------------------|----------------------------|
| 1) Combustion head | 8) Fan motor |
| 2) Insulating gasket | 9) photocell |
| 3) Burner coupling flange | 10) Pump |
| 4) Combustion head adjustment knob | 11) Ignition transformer |
| 5) Solenoid valves | 12) Pressure control valve |
| 6) Air adjustment servomotor | |
| 7) Electrical panel | |

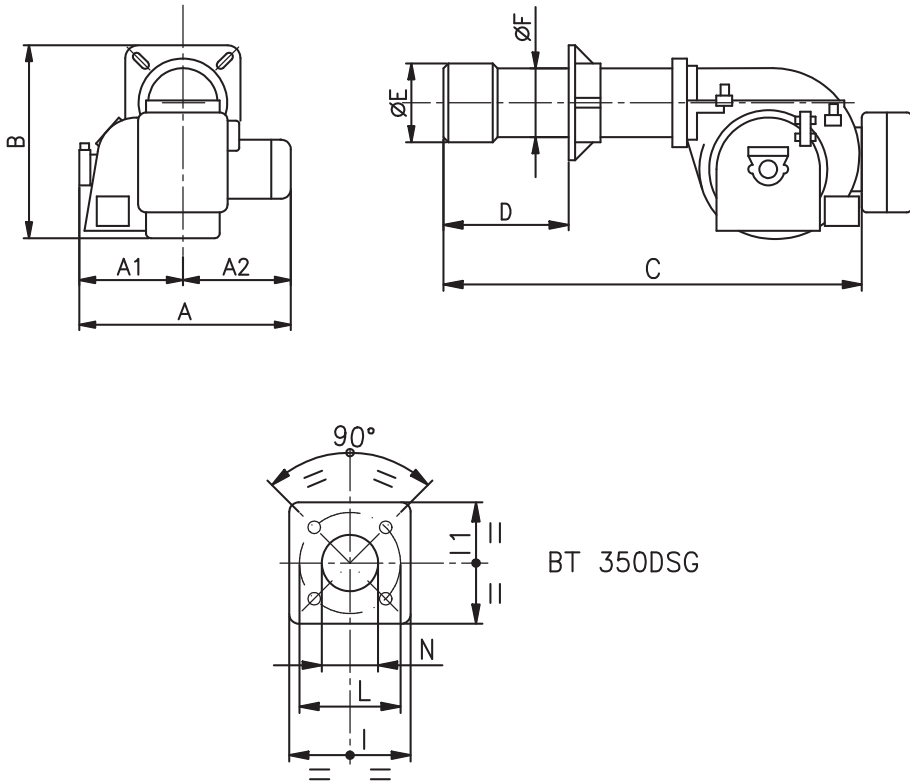

MOD.	OVERALL DIMENSIONS												
	G	A1	A2	B	C	D	E Ø	F Ø	E	I1	L	M	H
BT 350 DSG	1050	525	525	920	1960	350 ÷ 560	360	275	440	440	400÷540	M 20	365

OPERATING RANGE

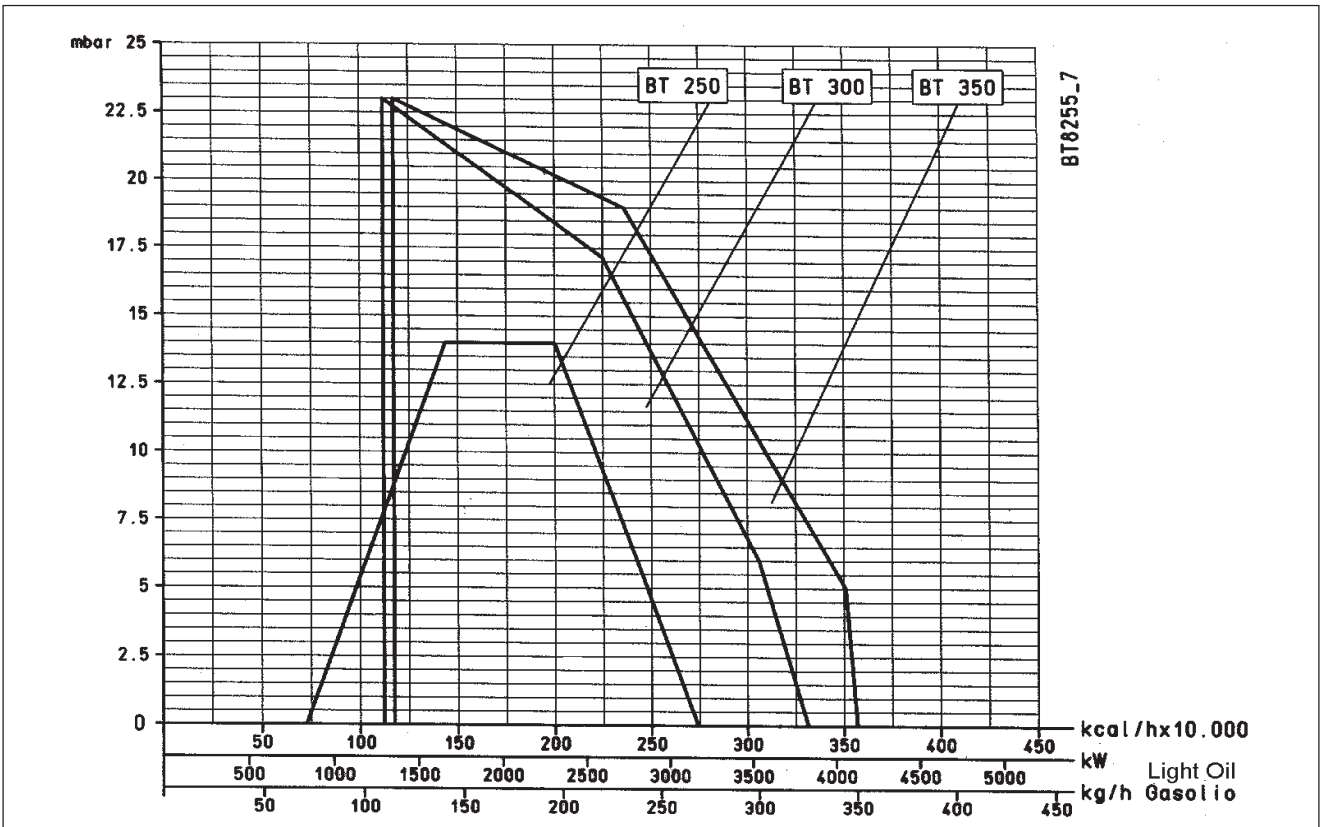

PRELIMINARY REMARKS FOR A PROPER INSTALLATION

Before proceeding with the installation make sure that:

- 1) The chimney (cross section and height) complies with the boiler manufacturer's instructions and legal provisions.
- 2) Where a refractory lining needs to be made for the combustion chamber (if the type of boiler requires it) then, it is necessary to make it according to the specific instructions of the boiler manufacturer.
- 3) The burner power supply should be arranged as indicated in our diagram and the electrical connections on the burner should be pre-set for the mains voltage.
- 4) The fuel pipelines must comply with our diagrams.
- 5) The nozzle or the nozzles fitted on the burner should be suitable for the boiler capacity; replace them with others, if necessary. Under no circumstances should the delivered quantity of fuel exceed the maximum amount required by the boiler and the max. amount permitted for the burner. Bear in mind that the combustion head has been designed for nozzles with a 45° spray angle. There are only special cases where nozzles can be fitted with a different spray angle; in these cases, however, make sure that the nozzle with a different spray angle will not cause any problems (flame separation, disk or combustion head fouling, violent ignition, etc.).
- 6) When removing the protective plastic cap from the nozzle seat be careful because if the sealing surface is indented (a light scoring would be enough) it will cause fuel dripping.
- 7) Make sure that the burner head enters the combustion chamber according to the boiler manufacturer's instructions.
- 8) Before connecting the flexible pipes, remove the protective plastic caps inserted in the pump fittings.

FIXING THE BURNER TO THE BOILER

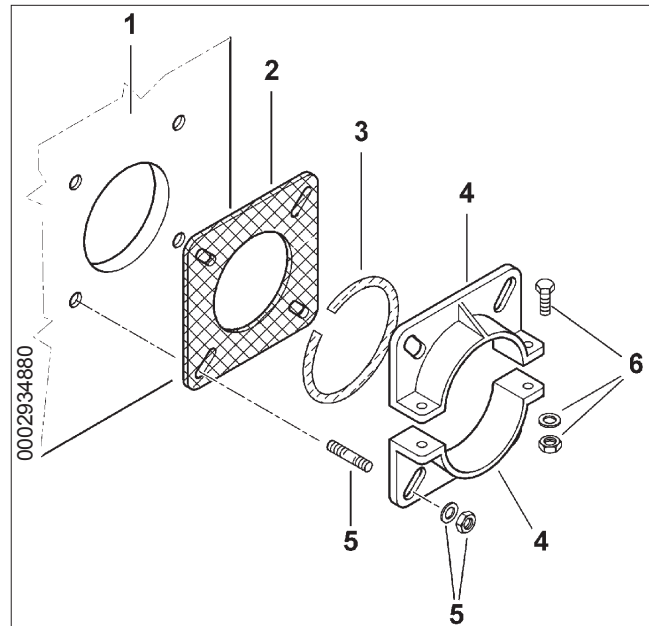

- 1 - Boiler plate
- 2 - Flange in insulating material
- 3 - Seam in insulating material
- 4 - Burner coupling flange
- 5 - Stud bolts, washers and nuts for fastening to the boiler
- 6 - Nuts screws and washers to fasten the flange to the sleeve

ASSEMBLING THE HEAD UNIT

Disassemble the end part of the combustion head to insert the insulating flange 2 between the burner and the boiler plate 1.

- a) Adjust the position of the coupling flange 4 by loosening the screws 6 so that the combustion head penetrates into the furnace to the extent recommended by the generator manufacturer.
- b) Place the insulating gasket 3 on the sleeve.
- c) Fasten the head unit to the boiler 1 by means of the stud bolts, washers and the nuts provided 5.
- d) Completely seal the gap between the burner sleeve and the hole in the refractory material inside the boiler door with suitable material.

ELECTRICAL CONNECTIONS

The electrical connections to the burner are minimal. It is advisable to make all electrical connections with flexible electrical wire. Electric lines should be at an adequate distance from hot parts.

Make sure that the power line to which the unit will be connected, has frequency and voltage suitable for the burner. Make sure that the main power line, the relative fuse-equipped switch (essential) and any limiter are capable of withstanding the maximum current absorbed by the burner.

For details see the specific wiring diagrams for each individual burner.

FUEL PIPELINES (DIESEL)

The following description covers merely the basic requirements for an efficient operation. The unit is equipped with a self-suction pump, capable of drawing oil directly from the tank also for the first fill-up. This statement holds only if the required conditions exist (refer to table of distances and difference in levels). To ensure an efficient operation, it is better to install suction and return pipes with welded fittings and to avoid the use of threaded connections which often cause air infiltration interfering with pump operation and consequently with the burner.

Where a removable fitting is required, use the welded flange method inserting a fuel resistant gasket to obtain a positive sealing. For systems requiring pipes with a relatively small diameter we recommend the use of copper pipes. For unavoidable joints we recommend the use of biconic fittings. The annexed tables show the indicative diagrams for the different types of systems depending on the position of the tank in respect to the burner.

The suction pipe should run up-slope towards the burner to prevent possible formation of gas bubbles. Where several burners are installed in one boiler room, it is essential for every burner to have its own suction pipe. Only return pipes can lead to a single manifold pipe with an adequate cross section leading to the tank. Never connect the return pipe directly to the suction pipe. It is a good practice to properly heat-insulate the suction and return pipes to prevent cooling which would otherwise affect the unit efficiency. Pipe diameters (to be strictly complied with) are listed in the following table. The maximum amount of vacuum that the pump can withstand noiselessly under normal operating conditions is 35 cm Hg; if this limit is exceeded normal pump operation will no longer be guaranteed. Maximum suction and return pressure = 1 bar.

AUXILIARY PUMP

In some cases (excessive distance or difference in level) it is necessary to install a "loop-type" supply system with an auxiliary pump, thus avoiding the burner pump from being directly connected to the tank.

In this case the auxiliary pump can be put into operation when the burner is started up and cut-off when it stops.

The electric wiring of the auxiliary pump is made by connecting the coil (230 V) which controls the pump remote control switch of the pump to the terminals "N" (equipment terminal board) and "R" (downstream the motor remote control switch).

It is important to strictly comply with the provisions set forth below:

- The auxiliary pump should be installed as near as possible to the fuel to be sucked.
- The head should meet the requirements of the system used.
- We recommend a delivery rate equal at least to that of the burner pump.
- Connection pipes should be sized to cope with the delivery rate of the auxiliary pump.
- Avoid electrically connecting the auxiliary pump directly to the remote control switch of the burner motor.

PIPELINE TABLE FOR BURNERS MODEL BT 350 DSG

GRAVITY FEED SYSTEM

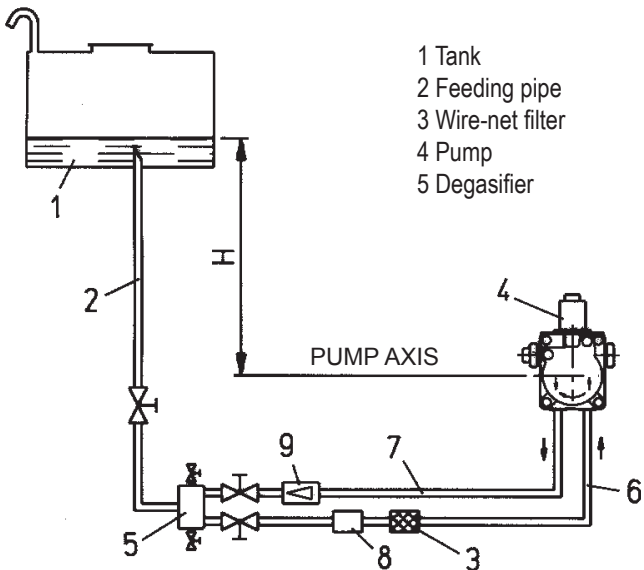

- 1 Tank
- 2 Feeding pipe
- 3 Wire-net filter
- 4 Pump
- 5 Degasifier

- 6 Suction pipe
- 7 Burner return pipe
- 8 Automatic fuel interception device at burner shut off
- 9 One-way valve

H metres	L total metres	
	Ø i= 3/4"	Øi. 20 mm
1	40	40
1.5	45	45
2	45	45
2.5	45	50
3	50	50

SIPHON FEED SYSTEM WITH FEED FROM THE TOP OF THE TANK

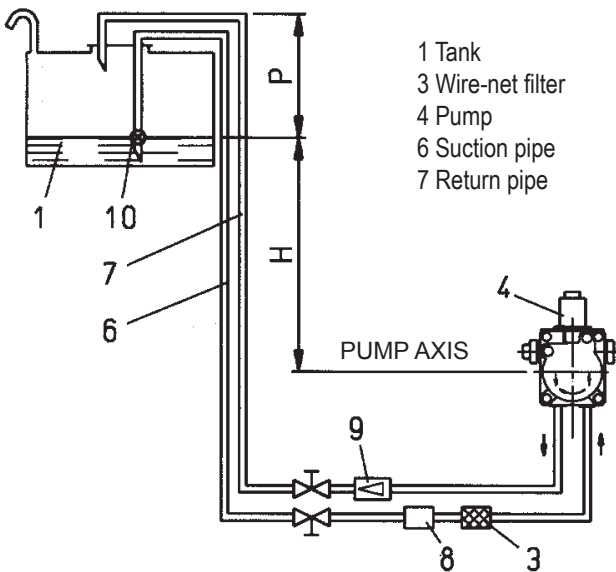

- 1 Tank
- 3 Wire-net filter
- 4 Pump
- 6 Suction pipe
- 7 Return pipe

- 8 Automatic fuel interception device at burner shut off
- 9 One-way valve
- 10 Foot valve

H metres	L total metres	
	Ø i= 3/4"	Øi. 20 mm
1	40	40
1.5	45	45
2	45	45
2.5	45	50
3	50	50

Dimension P = 3.5 m. (max.)

SUCTION FEED SYSTEM

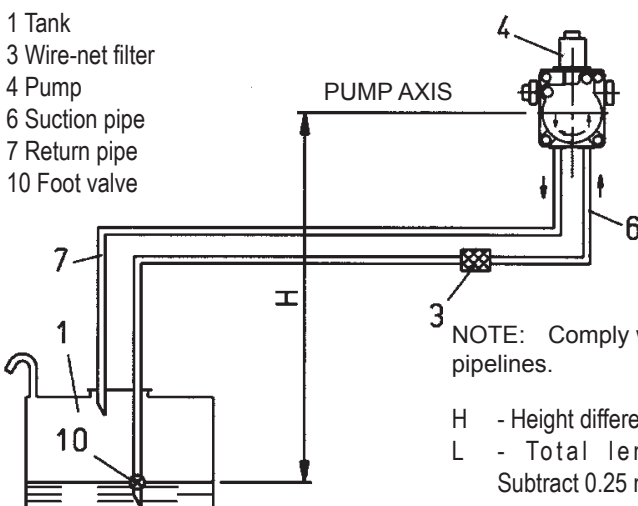

- 1 Tank
- 3 Wire-net filter
- 4 Pump
- 6 Suction pipe
- 7 Return pipe
- 10 Foot valve

H metres	L total metres	
	Ø i= 3/4"	Øi. 20 mm
0.5	34	34
1	29	29
1.5	24	24
2	19	19
2.5	14	14
3	9	9
3.5	3.5	3.5

NOTE: Comply with the regulations in force for any components missing in the pipelines.

H - Height difference between minimum fuel tank level and pump axis.
 L - Total length of pipeline, including vertical length.
 Subtract 0.25 mt. for every bend or gate valve.

FEED SYSTEM HYDRAULIC DIAGRAM FOR SEVERAL DIESEL FUEL OR HEAVY OIL BURNERS WITH MAXIMUM NOMINAL VISCOSITY (5 °E at 50 °C)

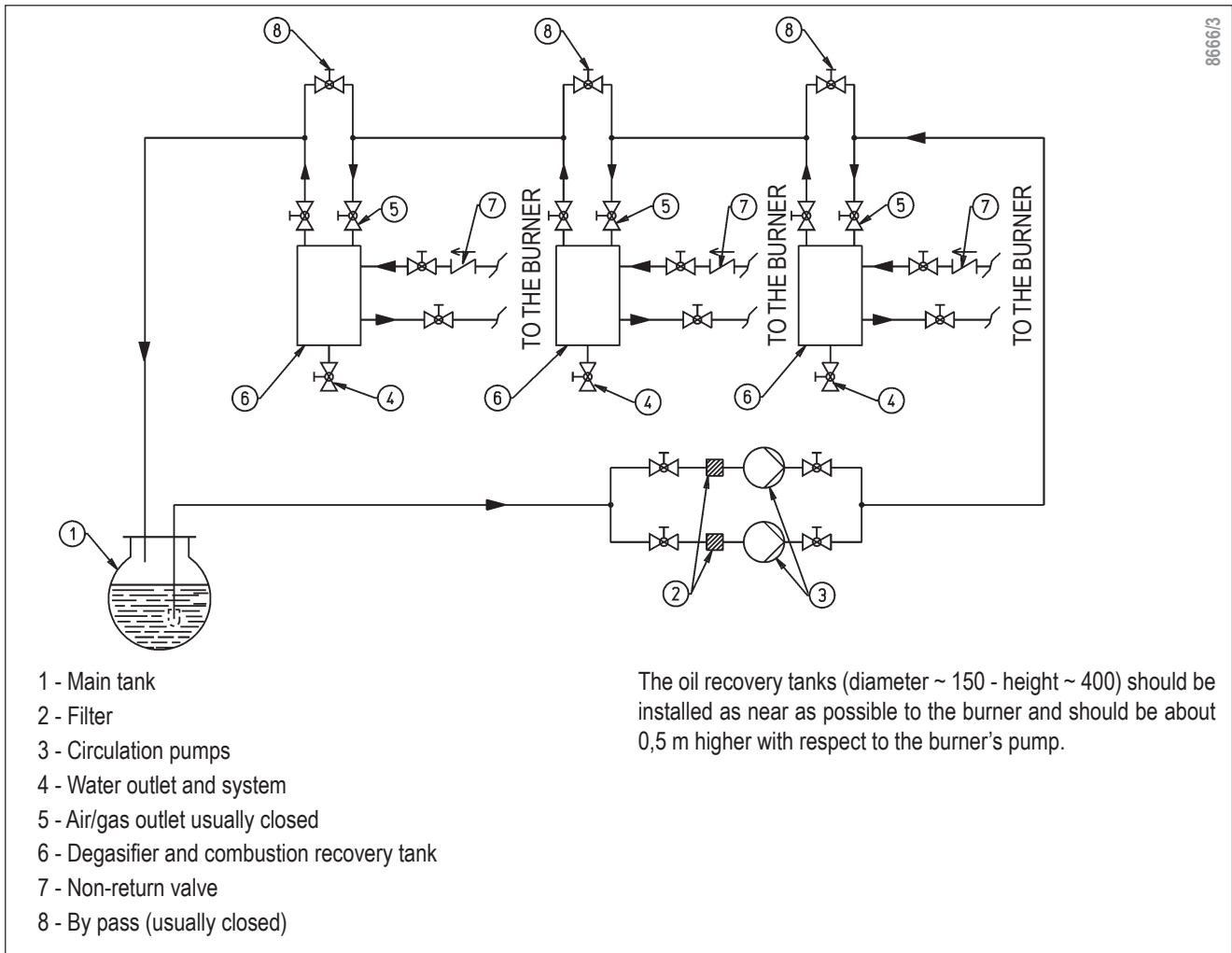

OPERATION DESCRIPTION

Turning on the switch on the equipment, if the regulation and safety thermostats allow it, the current reaches the control electrical equipment that starts the motor and the ignition transformer.

The motor turns the fan that carries out the pre-ventilation with the combustion chamber air. At the same time, the operation of the pump causes the diesel to circulate inside the ducts expelling any gas bubbles through the return valve. During the pre-ventilation phase the motor that activates the combustion air shutter opens it in the second flame position (pre-ventilation with air open). Then, the air shutter is returned to the first flame position for ignition. This "pre-wash" stage ends when the solenoid valve "1" (open in standby position) closes stopping the flow of the diesel towards the tank. As the solenoid valve "1" closes, the pressure inside the delivery ducts increases.

When the diesel pressure reaches 7 bar, it opens the mechanical valve located in the atomiser unit. Therefore, the diesel reaches the first flame nozzle and from this it enters into the combustion chamber finely atomised. The pressure stabilises at a value of approx. 10 bar since the first flame pressure regulator is adjusted to this value.

The atomised diesel comes out of the nozzle and is ignited by the charge of the electrodes that has generated upon motor start up. If the flame appears regularly, the programmer gets past the lock-out position and activates the motor that controls the combustion air shutter taking it to the second flame position.

During this operation an adjustable cam activated by the same shutter motor, closes an electric contact that supplies current to the solenoid valve "2" that intercepts the diesel flow through the first flame pressure regulator.

The first flame pressure regulator is therefore excluded and the pressure increases up to the value at which the pressure regulator incorporated in the pump (16 bar) is set.

The 16 bar pressure has also an effect on the mechanical valve that up to a pressure of 13 bar prevents the fuel from flowing toward the second nozzle. Therefore, the valve is opened by the pressure and the second nozzle starts working. The 16 bar pressure has now effect on the two nozzles.

When the equipment works at 16 bar, it is at its maximum capacity.

Note: It is clear from the above that the choice of nozzles, depending on the total capacity (2 nozzles working) required, must be made taking into account the capacity corresponding to the working

pressure of 16 bar using diesel fuel. Bear also in mind that as the burner is working with only the first flame activated, the first nozzle fuel supply corresponds to the values indicated on the 10 bar table since the first flame pressure regulator is set to this value. It is of course possible to vary within wide limits the ratio between the first and the second flames by replacing the nozzles. However, bear in mind that, in order to achieve a proper operation, fuel supply using the first flame should not be lower than the minimum capacity (indicated on the rating plate) for the burner. A lower capacity could make ignition difficult and the combustion obtained with the first flame alone might not be optimal.

As the flame is present inside the combustion chamber, the burner is controlled and monitored by the photocell and thermostats. The programmer continues its travel and deactivates the ignition transformer. The burner is lit working at full rate. If the program is interrupted (due to a power supply failure, manual action or the intervention of the thermostat, etc.) during the pre-wash stage, the programmer returns to its starting position and automatically repeats the entire burner ignition sequence. When the temperature or the pressure reaches that set by the thermostat or pressure switch, the burner stops. The equipment resumes operation automatically as the temperature or pressure value has reduced its value by the necessary amount.

If, during operation the flame is lacking for any reason, the photocell activates immediately (one second) and stops the relay supply and turns it off. Therefore, the washing solenoid valve deactivates and quickly bleeds out the existent pressure and the diesel fuel atomised spray is intercepted by the automatic closing of the atomiser unit valve as soon as the pressure drops below 7 bar.

In this case, the ignition sequence is automatically repeated and, if the flame re-ignites as usual, the burner starts working again as usual, if not (irregular flame or fails to light completely) the equipment goes automatically into lock-out.

HYDRAULIC DIAGRAM

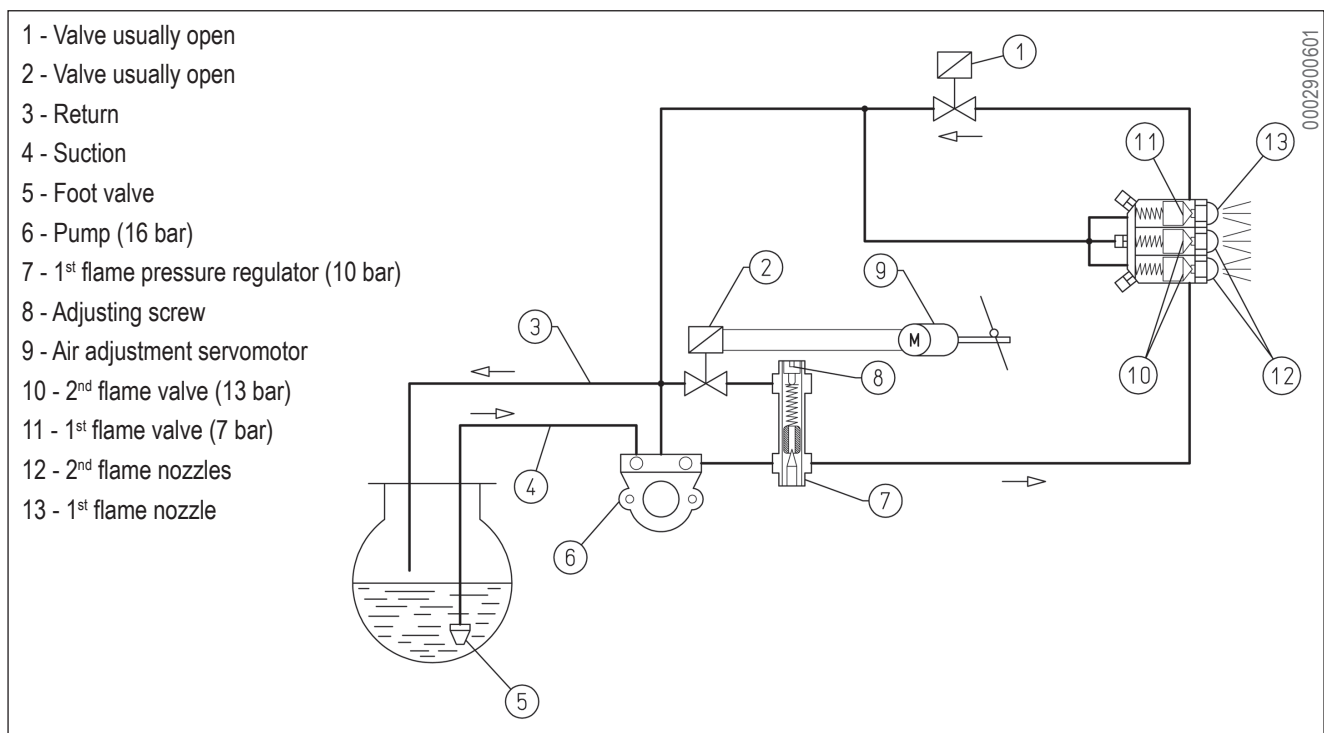

EQUIPMENT FEATURES

Equipment and relative programmer	Safety time in seconds	Pre-ventilation and pre-wash time in seconds	Post-ignition in seconds	Time between 1 st and 2 nd flame in seconds
LAL 1.25 Cyclic relay	5	22.5	15	7.5



FIRST FILLING UP OF PIPELINES

After making sure that the protective plastic caps inside the pump fittings have been removed, proceed as follows:

- 1) Move the switch placed on the burner to the "0" position. This operation prevents the burner from activating automatically.
- 2) Make sure, in case of a three-phase burner, that the motor revolves anti-clockwise when you are watching it from the pump side. The rotation direction can be determined also watching the rotation direction of the fan through the inspection window on the back of the scroll. To start the motor, close the remote control switch manually (pressing on the mobile part) for a few seconds and watch the rotation direction of the fan. If it is necessary to reverse the rotation direction, reverse the two phases on the line input terminals (L1 - L2 - L3).

Note: To positively determine the rotation direction, wait until the fan turns very slowly because it is quite easy to misinterpret the rotation direction.

- 3) Disconnect the flexible pipes, if they have already been connected, from both suction and return piping.
- 4) Immerse the end of the suction flexible pipe into a vessel containing either lubricating oil or fuel oil (do not use low viscosity products such as diesel fuel, petrol, gasoline, kerosene, etc.).
- 5) Now press on the mobile part of the motor remote control switch to start up the motor and the pump. Wait until the pump has drawn 1 or 2 cups of lubricant, then stop. This will prevent the pump from running dry and will increase the suction power.

Note: Pumps operating at 2800 r.p.m. must not work dry otherwise they will seize in a very short time.

- 6) Now connect the flexible pipes to the suction line and open all the gate valves fitted on this line and any other similar fuel cut-off device.
- 7) Now press on the mobile part of the motor remote control switch to start up the pump that extracts the fuel from the tank. When you see the fuel coming out of the return line (not yet connected), stop.

Note: If the piping is long, it may be necessary to bleed the air out through the cap; if the pump is not fitted with a cap, remove the cap from the pressure gauge.

- 8) Connect the return flexible pipe to the return line and open the valves fitted on this pipe. Now the burner is ready for ignition.

IGNITION AND ADJUSTMENT

Before igniting the burner make sure:

- a) The feeding line connections to thermostats or pressure switches are made exactly according to electric diagram of the appliance.
- b) There is fuel in the tank and water in the boiler.
- c) All the gate valves fitted on the diesel oil suction and return pipes should be open; the same thing applies to any other fuel cut-off device.

- d) The exhaust of combustion products takes place freely (boiler and chimney gate valves open).
- e) Make sure that the burner head penetrates into the combustion chamber according to the instructions of the boiler manufacturer. The burner is equipped with a coupling flange to the boiler, which slides on the burner head.

- f) The nozzles fitted on the burner should be suitable for the boiler capacity; replace them with others, if necessary. Under no circumstances should the delivered quantity of fuel exceed the maximum amount required by the boiler and the max. amount permitted for the burner. Bear in mind that the combustion head has been designed for nozzles with a 45° spray angle.

Note: To obtain a proper ignition and combustion using the first flame alone, the fuel supply should not be considerably lower than the minimum capacity (indicated on the plate) for the specific burner.

Note: The burner has a switch to pass manually from the 1st to the 2nd stage.

To ignite the burner proceed as follows:

- 1) Disconnect the thermostat (if connected) to prevent second flame activation.
- 2) Slightly open the air regulator (0002904000 / 0002904010) and let in an amount of air deemed necessary for burner operation with the 1st flame and lock it in this position; set the air control device in an intermediate position on the combustion head (see chapter "Adjusting the air on the combustion head").
- 3) Turn on the main switch and the equipment main switch.
- 4) The programmer activates and performs the pre-set program, activating the devices of which the burner consists. The burner ignites as described in chapter "Operation description".
- 5) When the burner is operating with the 1st flame, adjust the amount of air necessary to ensure an efficient combustion (0002904000 / 0002904010). It is better if the amount of air for the 1st flame is slightly reduced in order to ensure a perfect ignition even in the most critical conditions.
- 6) After adjusting the air for the 1st flame the burner stops, cutting off the voltage to the main switch. The terminals of the 2nd flame thermostat terminal board connect and the first and second stage switch moves to the second stage position.
- 7) Adjust the combustion air for the second flame (0002904000 / 0002904010)
- 8) The equipment activates again, it starts and automatically switches to the 2nd flame established by the programmer according to the pre-set program.
- 9) With the equipment operating with the 2nd flame, adjust (0002904000 / 0002904010) the amount of air necessary to ensure efficient combustion with the airflow necessary to ensure good combustion. Subsequently check combustion with the special instruments. In the absence of proper instrumentation use flame colour as a guide. We recommend that the adjustment is performed so as to obtain a soft light orange flame; avoid red flames with smoke and white flames with an exaggerated excess of air. The air regulator should be in a position to allow a percentage of carbon dioxide (CO₂) in the smoke, varying from

min. 10% to max. 13% with a smoke number not exceeding 2 (Bacharach scale). We remind you that for the first flame is preferable to limit the quantity of air to the lowest amount possible needed for safe ignition, even in the most difficult circumstances.

ADJUSTING THE DISTANCE BETWEEN DISK AND NOZZLE

The burners are equipped with a device that allows the distance between disk and nozzle to be varied. The factory set distance between disk and nozzle should be reduced only if you notice that the cone of atomised fuel coming out of the nozzle wets the disk fouling it.

ADJUSTING THE AIR ON THE COMBUSTION HEAD

The combustion head has a control device that allows the air passage between the disk and the combustion head to be opened (move backward) or closed (move forward).

By closing the passage, it is thus possible to obtain a high pressure upstream of the disk also for low flow rates. The high speed and turbulence of the air provides for its greater penetration into the fuel and therefore an excellent mixture and flame stability. High air pressure upstream of the disk may be necessary to prevent flame fluctuations, this is particularly essential when the burner works on the furnace that is pressurised and/or at a high thermal load.

It is clear from the above that the device that closes the air to the combustion head must be set at a position such as to always obtain very high air pressure behind the disk. It is advisable to adjust it in such a way as to obtain a closure of the air at the combustion head that will require a significant opening of the air shutter that regulates the suction flow from the burner fan. This must of course be the case when the burner is working at the required maximum supply. In practice you have to start the adjustment with the device that closes the air at the combustion head in an intermediate position, switching on the burner for an approximate adjustment as explained previously.

When the maximum required supply is reached, correct the position of the device closing the air on the combustion head by moving it forwards or backwards so as to have a suitable air flow for the delivery, with suction air adjustment shutter sensibly open.

When reducing the air passage on the combustion head, avoid closing it completely. Perfectly centre with respect to the disk. Remember that imperfect centring of the combustion head with respect to the disk may result in bad combustion and overheating of the head with its subsequent rapid deterioration. Check centring by looking through the inspection hole placed on the back part of the burner, then, tighten firmly the two screws fastening the air control device on the combustion head.

Note: Check that ignition is correct because if the regulator is shifted forward, the outgoing air speed may be too high to permit ignition. In such a case, it is necessary to move the regulator backwards, degree by degree, until reaching the position in which the ignition is regular and accept this new position as definitive. We remind you that for the first flame is preferable to limit the quantity of air to the strictly lowest amount

possible needed for safe ignition, even in the most difficult circumstances.

CHECKS

After starting up the burner, check the safety devices (photocell, block, thermostats).

- 1) The photocell is the flame control device and so it should trip if the flame extinguishes during operation (this check should be made after at least 1 minute from lighting up).
- 2) The burner should be capable of blocking itself and remain so when a normal flame does not come on during the ignition sequence and within the pre-set time on control device. The lock-out causes the immediate stop of the motor and burner and the switching on of the corresponding lock-out light indication. To check the operation of the photocell and lock-out system, proceed as follows:
 - a) Start the burner.
 - b) After at least one minute, remove the photocell from its seat and pull it out and simulate flame failure by covering the photocell (use a rag to close the window in the photocell support). The burner flame should go out.
 - c) Keep the photocell in the dark and the burner will start again, but the photocell does not see the light and the burner goes into lock-out within the time pre-set by equipment program. The equipment can be reset only manually by pressing the appropriate push-button. The lock-out efficiency has to be tested at least two times.
- 3) To check thermostat efficiency, make the burner work until the water inside the boiler reaches a temperature of at least 50°C. Then, use the thermostat control knob to reduce the temperature until you perceive an opening click and the burner stopping at the same time. The thermostat tripping should occur with a deviation of 5 ± 10 °C with respect to the control thermometer (boiler thermometer). Alternatively, change the setting of the thermostat scale making it correspond to that of the thermometer.

USING THE BURNER

The burner operates fully automatically: it is activated by switching on the main switch and the control panel switch. Burner operation is controlled by command and control devices, as described in the chapter "Operation description". The "lock-out" position is a safety position automatically taken up by the burner when a particular part of the burner or of the system is inefficient. Therefore, it is good practice, before "resetting" the burner and starting it up again, to check that there are no defects in the heating plant. The length of time that the burner stays in the "lock-out" position is without limit. To unlock, push the appropriate button. Lock-outs can be caused by transitory irregularities (a little water inside the fuel, air inside the piping, etc.); in these cases, if the burner is locked it starts up as usual. When, however, lock-outs occur repeatedly (3 or 4 times), do not persist in trying to unlock the burner and after checking that there is fuel in the tank, ask for the assistance of your local Technical

Assistance Service to repair the fault.

MAINTENANCE

The burners do not require particular servicing. It is good practice, however, to perform the following operations, at least at the end of the heating season:

- 1) Disassemble the filters, nozzle, turbulator disk and the ignition electrodes and clean thoroughly with solvents (petrol, trichloroethylene, oil). Avoid using metallic tools to clean the nozzle (use wood or plastic).
- 2) Clean the photocell.
- 3) Have the boiler cleaned and the chimney as well, if necessary.

Note: The nozzle or nozzles should be replaced at least every two heating seasons. The replacement might be required more frequently.

DESCRIPTION OF THE TWO-STAGE BURNER OPERATION

The two stage burner always ignites with a limited amount of air and fuel (1st flame) and, subsequently, after a few seconds, it will switch to full air and fuel operation (2nd flame).

The ignition of the 2nd flame is subject to the authorisation of the control box and control device (pressure switch or thermostat). When the burner works at full rate it will remain in this position until it reaches the pressure or temperature limit pre-set on the control device (pressure switch or thermostat). The control device trips, disconnecting the 2nd flame (fuel and air), when the limit to which it has been pre-set is reached. Then the burner works only with the 1st flame.

Normally the 1st flame alone is not sufficient to keep the temperature or the pressure at the required limit, and so it will decrease until it reaches the limit to which the control device of the 2nd flame (pressure switch or thermostat) re-activates the total fuel and air delivery rate. If the burner operates only with the 1st flame, it will stop completely when the pressure or the temperature reaches the tripping point set on the control device (pressure switch or thermostat).

The burner starts up automatically again when the pressure or temperature falls below the limit to which the pressure switch or thermostat has been pre-set.

Note: It is normally not advisable to connect a burner working on a boiler for heating water for two-flame working. In this case the burner works (sometimes for long periods of time) with one flame alone, the boiler is insufficiently loaded and consequently the fuels come out at an extremely low temperature (lower than 180°C) generating soot at the chimney outlet. In addition, when the boiler is working at lower output than that indicated in the technical data, it is likely that acidic condensate and soot will form in the boiler, causing corrosion and clogging. When the two-flame burner is installed on a hot water boiler for heating use, it must be connected so that it works normally with both flames, completely stopping without passing to the first flame when the pre-set temperature is reached. In order for it to work in this way, do not install the second flame thermostat, and make a direct bridge connection between the equipment terminals. This ensures that only the capability of the burner to ignite at

low capacity is used for a gentle ignition, which is essential for boilers with a pressurised combustion chamber and also very useful for normal boilers with depression combustion chamber. The ignition start/stop command is subject to the usual operating or safety thermostats.

TROUBLESHOOTING

TYPE OF PROBLEM	POSSIBLE CAUSE	SOLUTION
The burner goes into lock-out with the flame on (Red lamp on). The fault is in the flame control device.	<ol style="list-style-type: none"> 1) Photocell severed or fouled with smoke 2) Insufficient draft 3) Photocell circuit severed 4) Fouled disk or orifice 	<ol style="list-style-type: none"> 1) Clean or replace it 2) Check all the smoke ducts in the boiler and in the chimney 3) Replace the unit 4) Clean
The burner goes into lock-out spraying fuel but the flame does not ignite (Red lamp on). The problem is in the ignition device, providing the fuel is in good condition (not polluted with water or other impurities) and sufficiently atomised.	<ol style="list-style-type: none"> 1) Ignition circuit severed 2) The ignition transformer leads have dried out. 3) The ignition transformer leads are not properly connected 4) Ignition transformer interrupted. 5) The electrode tips are not at the correct distance 6) The electrodes discharge to earth because they are dirty or due to cracked insulation; also check under the insulation clamps. 	<ol style="list-style-type: none"> 1) Check the entire circuit 2) Replace them 3) Lock 4) Replace it 5) Return them in the required position 6) Clean or replace them, if necessary
The burner goes into lock-out spraying fuel but the flame does not ignite. (red indicator lit).	<ol style="list-style-type: none"> 1) Pump pressure is not normal 2) Water in the fuel 3) Excessive combustion air flow 4) Air passage between disk and blast tube excessively closed 5) Nozzle worn or fouled 	<ol style="list-style-type: none"> 1) Remove it. 2) Remove it from the tank with a suitable pump (never use the burner pump for this purpose). 3) Reduce combustion air flow 4) Rectify the position of the combustion head control device 5) Clean or replace it
The burner goes into lock-out without spraying fuel (Red lamp on).	<ol style="list-style-type: none"> 1) One phase missing 2) Inefficient electric motor 3) Diesel fuel not reaching the pump 4) No diesel fuel in the tank 5) Gate valve on the suction pipe closed 6) Nozzle clogged 7) Motor (three-phase) rotates in the wrong direction (see arrow) 8) Bottom valve leaking or jammed 9) Defective pump 10) Inefficient solenoid valve 11) Voltage too low 	<ol style="list-style-type: none"> 1) Check the supply line 2) Repair or replace it 3) Check the suction pipe 4) Fill it up 5) Open it 6) Remove and clean it thoroughly 7) Change one phase in the supply switch 8) Remove and clean it 9) Replace it 10) Check and replace, if necessary 11) Contact the electric company
Noisy burner pump	<ol style="list-style-type: none"> 1) Pipe diameter too small 2) Air infiltration in the pipes 3) Dirty filter 4) Excessive distance between the tank and the burner or numerous accidental leakages (elbows, curves, bottlenecks, etc.) 5) Deteriorated flexible pipes 	<ol style="list-style-type: none"> 1) Replace it according to instructions 2) Check and eliminate infiltrations 3) Remove and wash it 4) Adjust the length of the suction pipe to reduce the distance 5) Replace them
Burner fails to start	<ol style="list-style-type: none"> 1) Thermostats (boiler or environment) or pressure switches open 2) Photocell in short circuit 3) Lack of voltage due to the main switch being off or meter maximum switch tripped or lack of voltage in the mains 4) Thermostat line not wired according to diagram or some thermostat has not activated 5) Fault in the appliance 	<ol style="list-style-type: none"> 1) Increase the value or wait until they activate due to natural reduction of the temperature or pressure 2) Replace it 3) Activate switches or wait for power to return 4) Check connections and thermostats 5) Replace it

TYPE OF PROBLEM	POSSIBLE CAUSE	SOLUTION
Defective flame with presence of sparks	<ol style="list-style-type: none"> 1) Atomising pressure too low 2) Too much combustion air 3) Inefficient nozzle, either fouled or worn 4) Water in the fuel 	<ol style="list-style-type: none"> 1) Restore it at the required rating 2) Reduce combustion air flow 3) Clean or replace 4) Drain it from the tank using a suitable pump. (Never use the burner pump for this purpose)
Flame not properly shaped with presence of smoke and soot	<ol style="list-style-type: none"> 1) Insufficient combustion air flow 2) Inefficient nozzle, either fouled or worn 3) Combustion chamber unsuitably designed or too small 4) Delivery nozzle inadequate with respect to the combustion chamber size 5) Refractory lining unsuitable or excessive 6) Boiler or chimney ducts clogged 7) Low atomising pressure 	<ol style="list-style-type: none"> 1) Increase the combustion air flow 2) Clean or replace 3) Modify or reduce the nozzle capacity with respect to the combustion chamber or replace the boiler 4) Increase nozzle delivery rate by replacing it 5) Modify it according to the boiler manufacturer's instructions 6) Clean them 7) Return it at the required value
Defective flame (flickering or protruding from combustion head)	<ol style="list-style-type: none"> 1) Excessive draught (only when there is an extractor in the chimney) 2) Inefficient nozzle, either fouled or worn 3) Water in the fuel 4) Dirty disk 5) Excessive combustion air flow 6) Air passage between disk and blast tube excessively closed 	<ol style="list-style-type: none"> 1) Adjust the suction fan speed by changing the pulley diameters 2) Clean or replace 3) Remove it from the tank with a suitable pump (never use the burner pump for this purpose). 4) Clean it 5) Reduce combustion air flow 6) Rectify the position of the combustion head control device
Corrosion inside the boiler.	<ol style="list-style-type: none"> 1) Boiler working temperature too low (below dew point) 2) High percentage of sulphur in the fuel 3) Smoke temperature too low (below 180 °C) 	<ol style="list-style-type: none"> 1) Increase the operating temperature 2) Change the type of fuel 3) Increase nozzle delivery rate by replacing it
Soot at chimney outlet	<ol style="list-style-type: none"> 1) Excessive cooling (below 180°C) of smoke before exit outflow, for an outside chimney not adequately heat insulated or cold air infiltration. 	<ol style="list-style-type: none"> 1) Improve insulation and close any opening letting cold air in.

LAYOUT DIAGRAM FOR DISK-NOZZLE-ELECTRODES

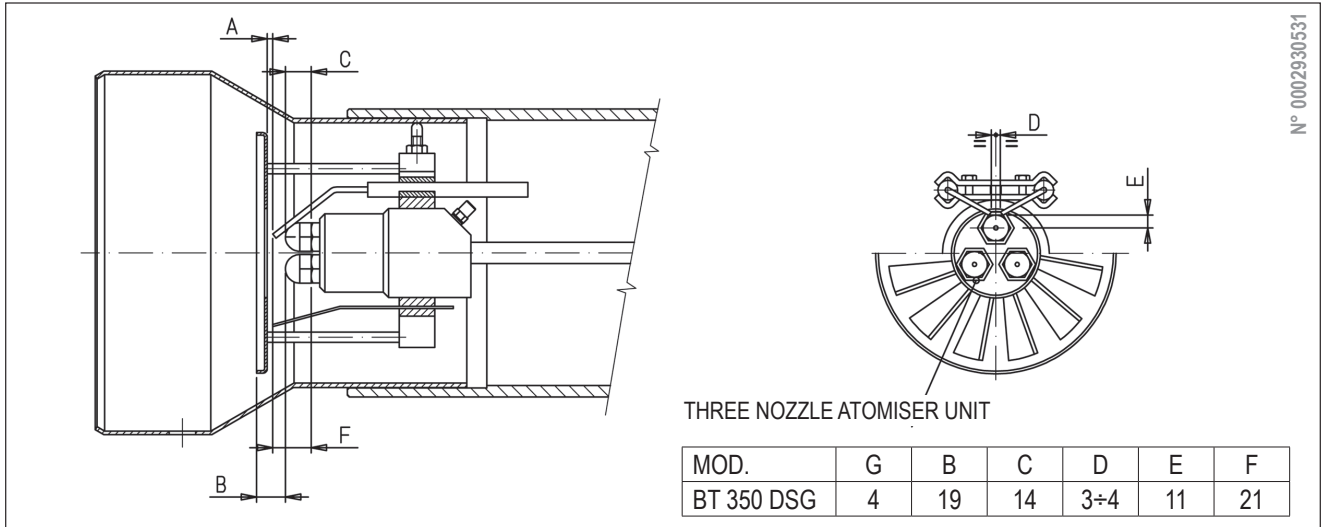
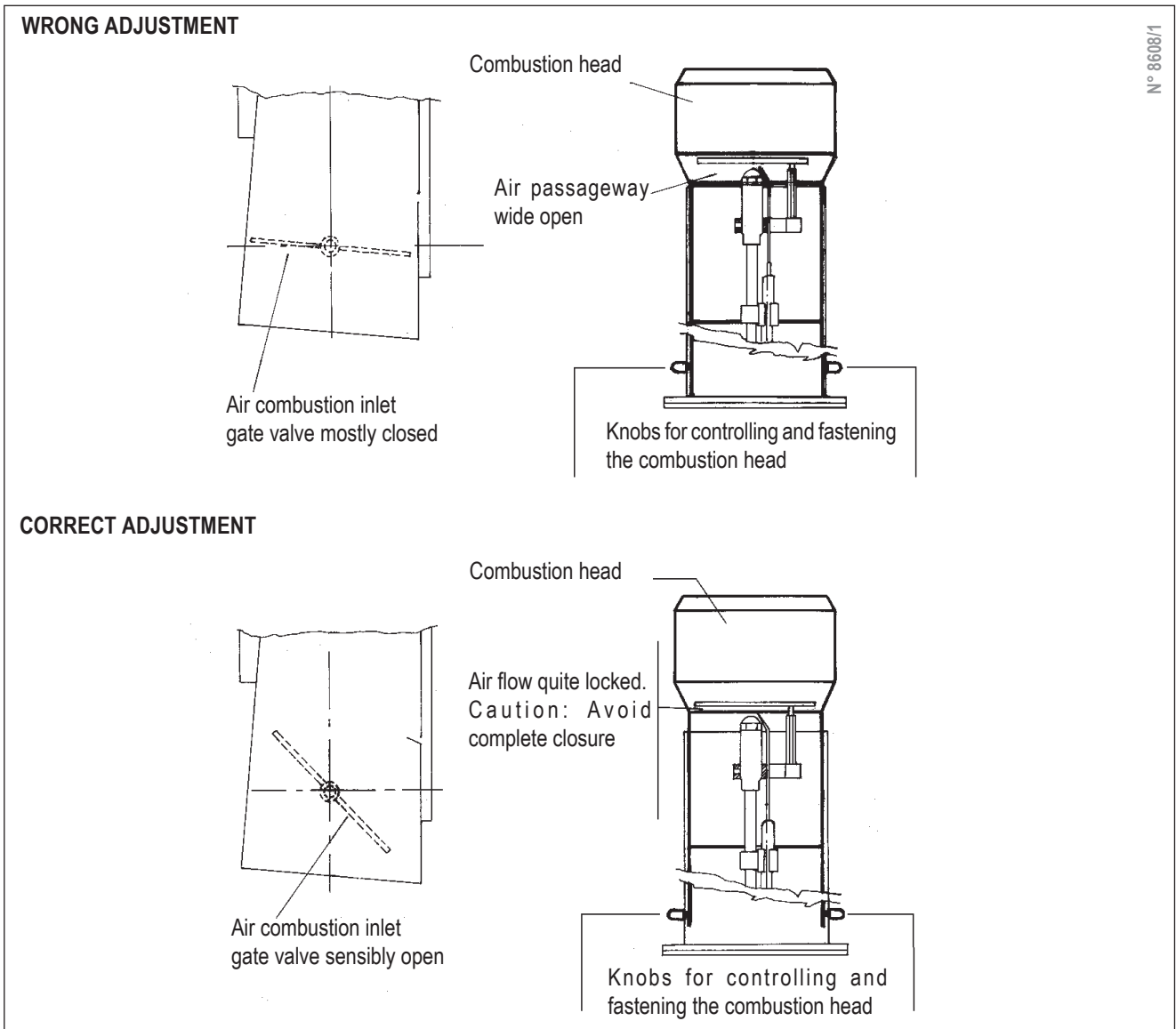
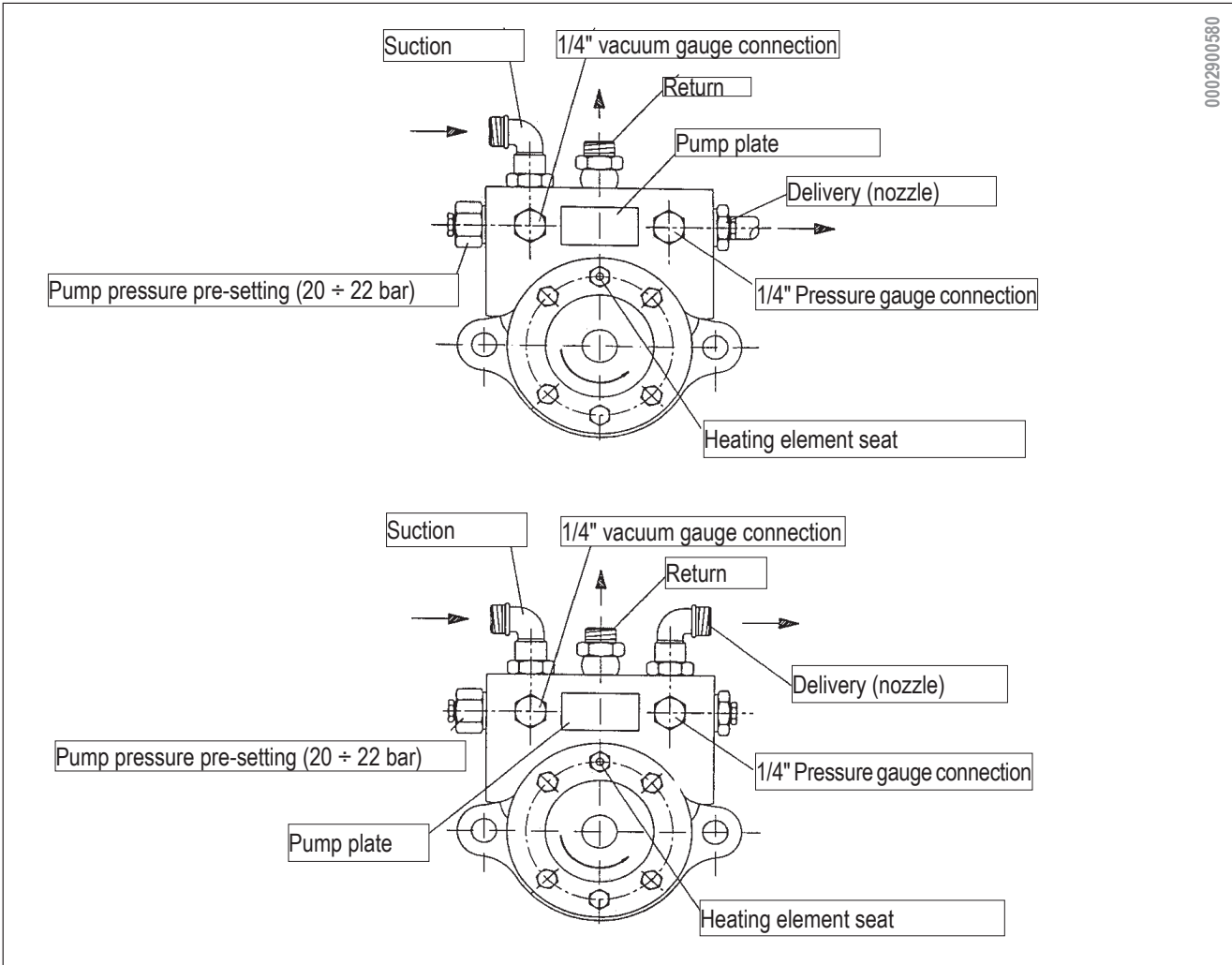

DIAGRAM ILLUSTRATING PRINCIPLE OF AIR CONTROL



BALTUR PUMP MODEL BT...

0002900580



NOZZLE FLOW-RATE TABLE FOR DIESEL FUEL

Nozzle	Pump pressure															Nozzle
	7	8	9	10	11	12	13	14	15	16	17	18	19	20	21	
G.P.H.	Nozzle output flow-rate															G.P.H.
0.40	1.27	1.36	1.44	1.52	1.59	1.67	1.73	1.80	1.86	1.92	1.98	2.04	2.10	2.15	2.20	0.40
0.50	1.59	1.70	1.80	1.90	1.99	2.08	2.17	2.25	2.33	2.40	2.48	2.55	2.62	2.69	2.75	0.50
0.60	1.91	2.04	2.16	2.28	2.39	2.50	2.60	2.70	2.79	2.88	2.97	3.06	3.14	3.22	3.30	0.60
0.65	2.07	2.21	2.34	2.47	2.59	2.71	2.82	2.92	3.03	3.12	3.22	3.31	3.41	3.49	3.58	0.65
0.75	2.38	2.55	2.70	2.85	2.99	3.12	3.25	3.37	3.49	3.61	3.72	3.82	3.93	4.03	4.13	0.75
0.85	2.70	2.89	3.06	3.23	3.39	3.54	3.68	3.82	3.96	4.09	4.21	4.33	4.45	4.57	4.68	0.85
1.00	3.18	3.40	3.61	3.80	3.99	4.16	4.33	4.50	4.65	4.81	4.96	5.10	5.24	5.37	5.51	1.00
1.10	3.50	3.74	3.97	4.18	4.38	4.58	4.77	4.95	5.12	5.29	5.45	5.61	5.76	5.91	6.06	1.10
1.20	3.82	4.08	4.33	4.56	4.78	5.00	5.20	5.40	5.59	5.77	5.95	6.12	6.29	6.45	6.61	1.20
1.25	3.97	4.25	4.50	4.75	5.00	5.20	5.40	5.60	5.80	6.00	6.20	6.35	6.55	6.70	6.85	1.25
1.35	4.29	4.59	4.87	5.13	5.38	5.62	5.85	6.07	6.28	6.49	6.69	6.88	7.07	7.26	7.44	1.35
1.50	4.77	5.10	5.41	5.70	5.90	6.24	6.50	6.75	6.98	7.21	7.43	7.65	7.86	8.06	8.26	1.50
1.65	5.25	5.61	5.95	6.27	6.58	6.87	7.15	7.42	7.68	7.93	8.18	8.41	8.64	8.87	9.09	1.65
1.75	5.56	5.95	6.31	6.65	6.98	7.29	7.58	7.87	8.15	8.41	8.67	8.92	9.17	9.41	9.64	1.75
2.00	6.30	6.80	7.21	7.60	7.97	8.33	8.67	8.99	9.31	9.61	9.91	10.20	10.48	10.75	11.01	2.00
2.25	7.15	7.65	8.15	8.55	8.97	9.37	9.75	10.12	10.47	10.85	11.15	11.47	11.79	12.09	12.39	2.25
2.50	7.95	8.50	9.01	9.50	9.97	10.41	10.83	11.24	11.64	12.02	12.39	12.75	13.10	13.44	13.77	2.50
3.00	9.54	10.20	10.82	11.40	11.96	12.49	13.00	13.49	13.96	14.02	14.87	15.30	15.72	16.12	16.52	3.00
3.50	11.13	11.90	12.62	13.30	13.95	14.57	15.17	15.74	16.29	16.83	17.34	17.85	18.34	18.81	19.28	3.50
4.00	12.72	13.60	14.42	15.20	15.94	16.65	17.33	17.99	18.62	19.23	19.82	20.40	20.95	21.50	22.03	4.00
4.50	14.31	15.30	16.22	17.10	17.94	18.73	19.50	20.24	20.95	21.63	22.30	22.95	23.57	24.19	24.78	4.50
5.00	15.90	17.00	18.03	19.00	19.93	20.82	21.67	22.48	23.27	24.04	24.78	25.49	26.19	26.87	27.54	5.00
5.50	17.49	18.70	19.83	20.90	21.92	22.90	23.83	24.73	25.60	26.44	27.25	28.04	28.81	29.56	30.29	5.50
6.00	19.00	20.40	21.63	22.80	23.92	24.98	26.00	26.98	27.93	28.84	29.73	30.59	31.43	32.25	33.04	6.00
6.50	20.67	22.10	23.44	23.70	25.91	27.06	28.17	29.23	30.26	31.25	32.21	33.14	34.05	34.94	35.80	6.50
7.00	22.26	23.79	25.24	26.60	27.90	29.14	30.33	31.48	32.58	33.65	34.69	35.69	36.67	37.62	38.55	7.00
7.50	23.85	25.49	27.04	28.50	29.90	31.22	32.50	33.73	34.91	36.05	37.16	38.24	39.29	40.31	41.31	7.50
8.30	26.39	28.21	29.93	31.54	33.08	34.55	35.97	37.32	38.63	39.90	41.13	42.32	43.48	44.61	45.71	8.30
9.50	30.21	32.29	34.25	36.10	37.87	39.55	41.17	42.72	44.22	45.67	47.07	48.44	49.77	51.06	52.32	9.50
10.50	33.39	35.69	37.86	40.06	41.73	43.74	45.41	47.20	48.90	50.50	52.00	53.50	55.00	56.40	57.80	10.50
12.00	38.20	40.80	43.30	45.60	47.80	50.00	52.00	54.00	55.90	57.70	59.50	61.20	62.90	64.50	66.10	12.00
13.80	43.90	46.90	49.80	52.40	55.00	57.50	59.80	62.10	64.20	66.30	68.40	70.40	72.30	74.30	76.00	13.80
15.30	48.60	52.00	55.20	58.10	61.00	63.70	66.30	68.80	71.10	73.60	75.80	78.00	80.20	82.20	84.30	15.30
17.50	55.60	59.50	63.10	66.50	69.80	72.90	75.80	78.70	81.50	84.10	86.70	89.20	91.70	94.10	96.40	17.50
19.50	62.00	66.30	70.30	74.10	77.70	81.20	84.50	87.70	90.80	93.70	96.60	99.40	102.20	104.80	107.40	19.50
21.50	68.40	73.10	77.50	81.70	85.70	89.50	93.20	96.70	100.10	103.40	106.50	109.60	112.60	115.60	118.40	21.50
24.00	76.30	81.60	86.50	91.20	95.70	99.90	104.00	107.90	111.70	115.40	118.90	122.40	125.70	129.00	132.20	24.00
28.00	89.00	95.20	101.00	106.40	111.60	116.60	121.30	125.90	130.30	134.60	138.70	142.80	146.70	150.50	154.20	28.00
30.00	95.40	102.00	108.20	114.00	119.60	124.90	130.00	134.90	139.60	144.20	148.70	153.00	157.20	161.20	165.20	30.00

1 mbar = 10 mmC.A. 100 Pa

1 kW = 860 kcal

Diesel density = 0,820 / 0,830 PCI = 10150

Special Heating Oil Density = 0,900 PCI = 9920

Domestic Heating Oil Density = 3,5 / 0,940 PCI = 9700

Heavy Oil Density = 0,970 / 0,980 PCI = 9650

PCI = Minimum calorific value

MOTOR "CONECTRON LKS 160" SETTING FOR AIR SHUTTER COMMAND IN FIRST FLAME POSITION

REFERENCE INDEX

ADJUSTABLE CAMS

I 2nd FLAME AIR ADJUSTING CAM (60°)

III UNUSED CAM (... °)

II 1st FLAME AIR ADJUSTING CAM (20°)

IV 2nd FLAME VALVE ACTUATING CAM (40°)

N° 0002934010

SETTING OF MOTOR "CONECTRON LKS 160" FOR AIR SHUTTER CONTROL IN SECOND FLAME POSITION

REFERENCE INDEX

ADJUSTABLE CAMS

I 2nd FLAME AIR ADJUSTING CAM (60°)

II TOTAL AIR CLOSURE (BURNER OFF) (0°)

III 1st FLAME AIR ADJUSTING CAM (20°)

IV 2nd FLAME VALVE ACTUATING CAM (40°)

N° 0002934000

WIRING DIAGRAM

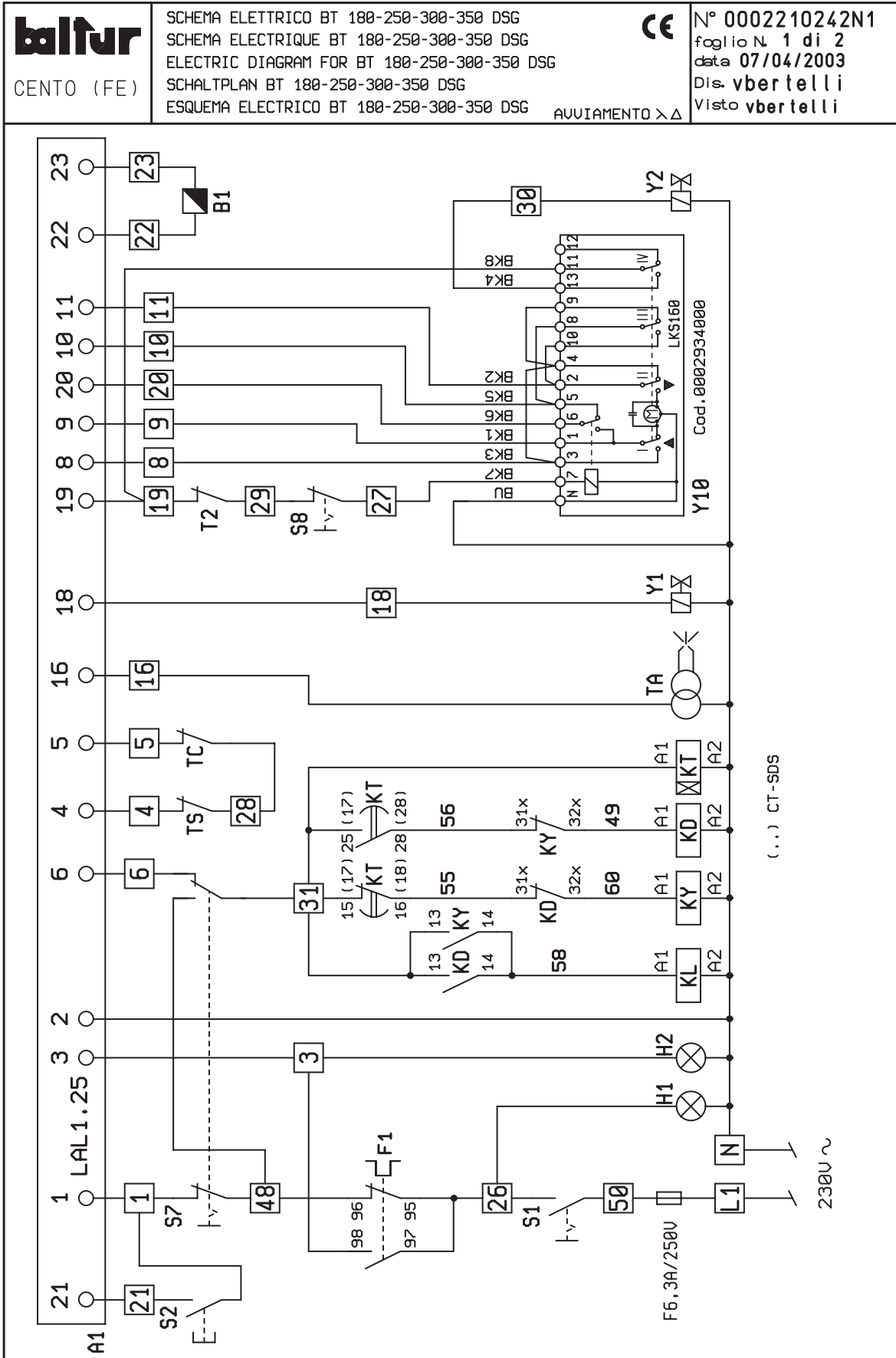

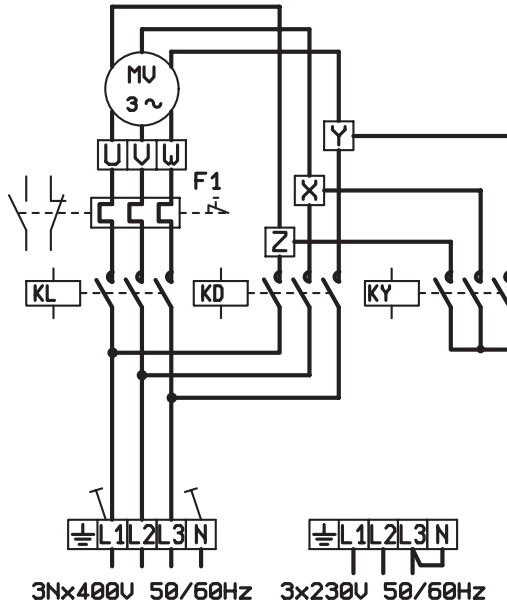

- H1 - SPIA DI MARCIA / OPERATION SIGNAL LAMP / BETRIEBSLAMPE / INTERRUPTOR DE ENCENDIDO
- H2 - SPIA BLOCCO BRUCIATORE / BURNER LOCK-OUT SIGNAL LAMP / BLOKONTROLLAMPE / LÁMPARA DE BLOQUEO
- S1 - INTERRUPTORE MARCIA-ARRESTO / ON-OFF SWITCH / EIN AUS SCHALTER / INTERRUPTOR ENCENDIDO APAGADO
- S2 - PULSANTE SBLOCCO APPARECCHIATURA / CONTROL BOX RESET / ENTSPERRKNOPF / BOTÓN DE DESBLOQUEO DE LA CAJA DE CONTROL
- S7 - PULSANTE CARICAMENTO TUBAZIONI / PIPELINE LOADING SWITCH / BEHALTERSBELOADUNGSKNOPFE / BOTÓN CARGA TUBERÍAS
- S8 - INTERRUPTORE 1°-2° STADIO / 1°-2° STAGE SWITCH / SCHALTER 1°-2° STUFE / INTERRUPTOR 1°-2° ETAPA
- F1 - RELE' TERMICO MOTORE VENTOLA / FAN MOTOR THERMIC RELAY / THERMISCHES RELAIS / RELÉ TÉRMICO MOTOR VENTILADOR
- A1 - APPARECCHIATURA / CONTROL BOX / STEURGERAT / CAJA DE CONTROL
- KL - CONTATTORE DI LINEA MOTORE VENTOLA / FAN MOTOR LINE CONTACTOR / LEITUNGSSCHALTER / CONTADOR DE LINEA MOTOR IMPULSOR
- KD - CONTATTORE TRIANGOLO MOTORE VENTOLA / FAN MOTOR TRIANGLE CONTACTOR / DREIECKSCHALTER / CONTADOR TRIÁNGULO MOTOR IMPULSOR
- KY - CONTATTORE STELLA MOTORE VENTOLA / FAN MOTOR STAR CONTACTOR / STERNSCHALTER / CONTADOR ESTRELLA MOTOR IMPULSOR
- KT - TEMPORIZZATORE / TIMER / ZEITGEBER / TEMPORIZADOR
- TC - TERMOSTATO CALDAIA / BOILER THERMOSTAT / KESSELTHERMOSTAT / TERMOSTATO CALDERA
- TS - TERMOSTATO DI SICUREZZA / SAFETY THERMOSTAT / SICHERHEITSTHERMOSTAT / TERMOSTATO DE SEGURIDAD
- Y1 - ELETTRORVALVOLA 1° STADIO / 1° STAGE ELECTROVALVE / MAGNETVENTIL 1° FLAMME / ELECTROÁLVULA 1° ETAPA
- Y2 - ELETTRORVALVOLA 2° STADIO / 2° STAGE ELECTROVALVE / MAGNETVENTIL 2° FLAMME / ELECTROÁLVULA 2° ETAPA
- TA - TRASFORMATORE D'ACCENSIONE / IGNITION TRANSFORMER / ZÜNDTRASFORMATOR / TRANSFORMADOR DE ENCENDIDO
- T2 - TERMOSTATO 2° STADIO / 2° STAGE THERMOSTAT / THERMOSTAT 2° FLAMME / TERMOSTATO 2° ETAPA
- B1 - FOTORESISTENZA / PHOTORESISTANCE / FOTOWINDERSTAND / FOTORESISTENCIA
- MU - MOTORE VENTILATORE / FAN MOTOR / BRENNERMOTOR / MOTOR VENTILADOR
- Y10 - SERVOMOTORE ARIA / AIR SERVOMOTOR / STELLMOTOR / SERVOMOTOR CLAPETA DE AIRE



Baltur S.p.A.
Via Ferrarese, 10
44042 Cento (Fe) - Italy
Tel. +39 051-6843711
Fax: +39 051-6857527/28
www.baltur.it
info@baltur.it